

BLY Series

Y-Type Manual Bellows Valves



Design and Engineering

- Bellows Design for High Purity and long cycle life.
- Compact Design
- 10Ra or 5Ra microinch internal surface
- Maximum Leak Rate of 4×10^{-9} atm cc/sec He
- Assembled and tested in a Class 10 cleanroom
- Downstream Purge connections are available

Application

- High-purity gas distribution system control
- High-purity gas valves for point-of-use service
- Superior containment and cleanliness for most critical valve applications
- Use with inert and most bulk gases

Material of Constructions

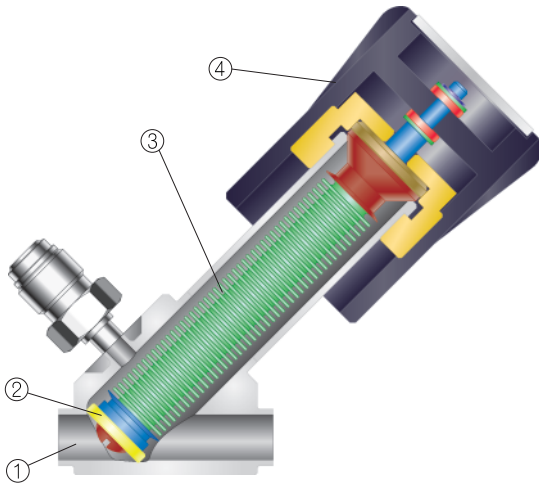

No.	Description	Material
1	Body	316L Single Melting(VOD) 316L Double Melting(VIM-VAR) 304 SS
2	Seat	PCTFE
3	Bellows	316L SS
4	Handle	ALUMINUM

Table of Dimensions

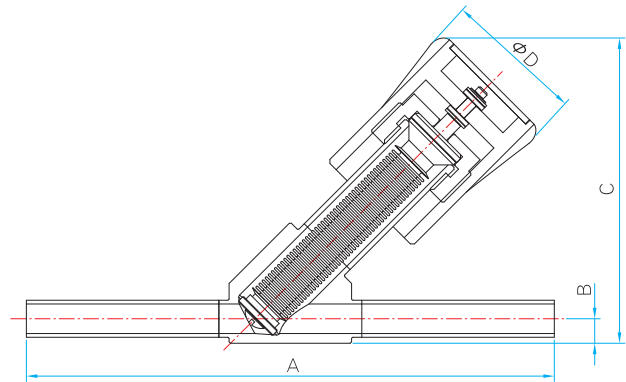

Size	A	B	C	D
1/2"	180	8.4	104.5	52
3/4"	200	11.5	110.0	60

All dimensions are in millimeters and Subject to change.

Specifications

Size	1/2"	3/4"
Cv Value	16	24
Max. Working Pressure	150 psig (1.034MPa)	
Max. Working Temp.	-10°C ~ 80°C	
Inboard Leak Rate		
Test pressure $\leq 2 \times 10^{-4}$ Torr	$\leq 4 \times 10^{-9}$ atm cc / sec He	
Holding Time ≥ 15 s		
Outboard Leak Rate		
Test pressure $\leq 2 \times 10^{-4}$ Torr	$\leq 4 \times 10^{-9}$ atm cc / sec He	
Holding Time ≥ 15 s		
Particle Inspection(EP Grade)		
Pressure : 100psi N2 gas	No count	
Sample Volume : 2.0std ft ³ /min		
0.1 μ m and larger		

Ordering Informations

BLY1

Valve Type Designator

- BLY1 : 1/2"
- BLY2 : 3/4"

BW

End Connection Designator

- BW : Butt Weld

8

Size Designator

- 8 : 1/2"
- 12 : 3/4"

H

Surface Grade

- A : AP grade
- B : BA grade
- H : EP grade

PG

Option

- PG : Purge Port

VV6L

Body Material

- S304 : 304 SS
- SM6L : Single Melting 316L
- VV6L : Double Melting 316L

■ QUALITY SYSTEM CERTIFICATES



ISO 9001
CERTIFICATE NO. GQC 212

ASME SECT III (MO)
CERTIFICATE NO. QSC 584

SAFETY in VALVE SELECTION

Proper installation, material compatibility, operation and maintenance of the valves is the responsibility of the user. The total system design must be taken into consideration to ensure optimal performance and safety.



Distributed by :